

#B5C-8151968-AA and B6C-8151968 1953-56 Ford Pickup Headliner Installation



HELPFUL TIP

MAKING INSTALLATION EASIER

We have found from experience that by dampening the headliner material with water makes it more flexible and less likely to break during installation.

Using a spray bottle filled with water, lightly spray the BACKSIDE of the side panels and the rear part of the headliner next to the rear window until the material becomes softer so that it can be formed more easily by hand.

INSTALLATION OF HEADLINER

IT IS NOT NECESSARY to remove the back window from the cab but it can make installation less frustrating. This may require using a new rear window seal if the old one is not reusable.

The rear of the headliner is supported by being tucked behind the window rubber seal and it can be difficult to tuck if the seal is aged and hardened. This is when the cardboard headliner can get kinked. By removing the window and the rubber seal before installation you can screw the headliner panels into position first then reinstall the glass and rubber seal over the headliner. TWO PATIENT PEOPLE are needed to do the installation smoothly.

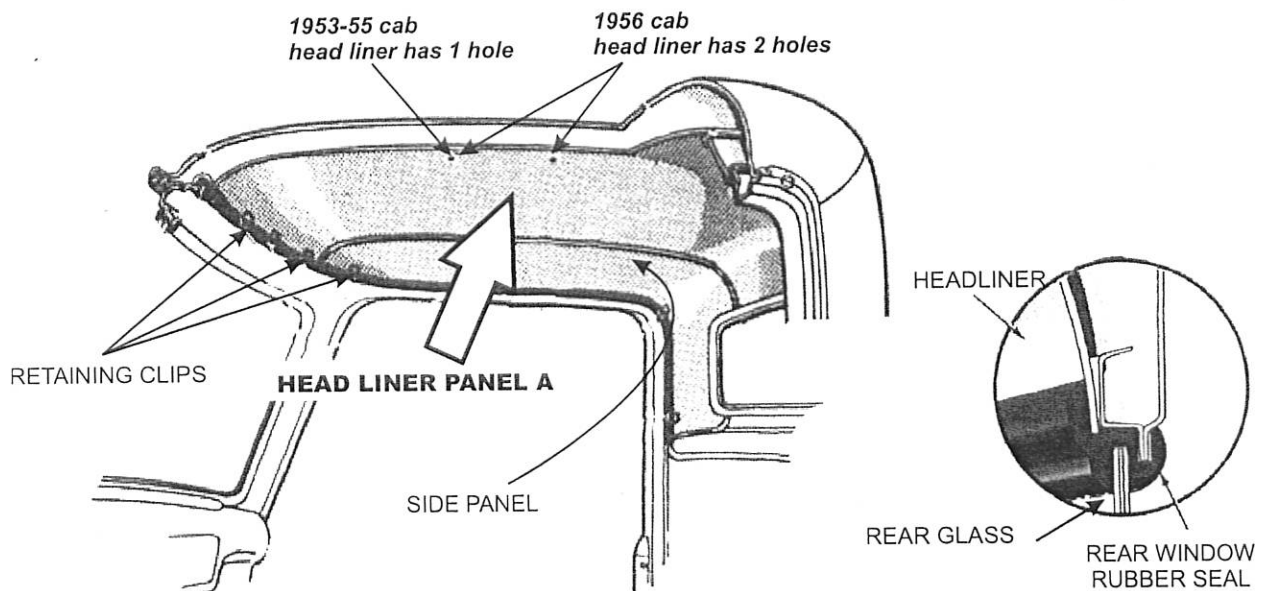

STEP 1

Remove the rear view mirror, sun visors and rear window if you choose to do so.

STEP 2

Place the large **HEAD LINER PANEL A** into position starting at the header panel above the windshield. For 1953-55 cabs line up the single hole in the center of the head liner and the header panel holes then screw the head liner in place. (1956 cabs line up the 2 holes in the center of the head liner). Work from front to back and tuck the head liner behind the upper rubber seal of the back window. Secure the head liner by attaching the retaining clips above the windshield.

STEP 3

The side panels which go over the doors can be attached in place starting at the back window and placing the panel behind the rubber seal and working towards the front. Attach with retaining clips above the door opening.

STEP 4

The panel beneath the back window goes behind the rubber seal and attached with screws at both ends.

STEP 5

Replace mirror, sunvisors and rear window if removed.



4140 Concord Parkway So., Concord, NC 28027
(704) 786-8139 email: info@dennis-carpenter.com
www.dennis-carpenter.com