

1952-54 Ford Car Windshield Rubber Installation

Applies to: BA-7003110-E

BA-7603110-D

BA-7003110-F

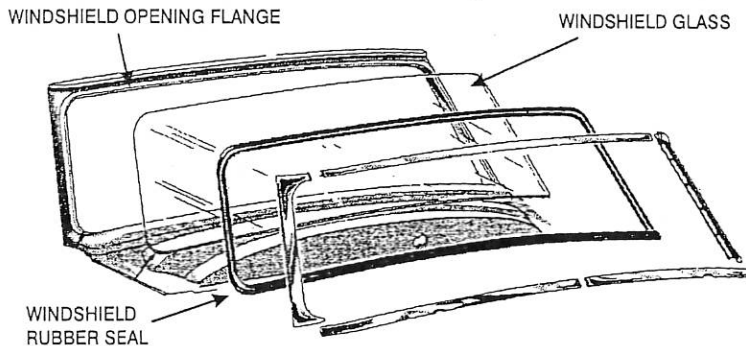

NOTE
It is recommended to use an auto glass sealer when installing the new rubber window seals to prevent possible leaking. Permatex Auto Glass Sealer 7651259 is one example.

Installing windshield rubber seal

1. Remove all old weather stripping and weather stripping sealer from the windshield opening flange. Clean the flange area thoroughly.
2. Trial fit the rubber seal onto the windshield. This allows you to orient how the seal should fit the on the glass. Remove seal and prepare it for sealer application.
3. Apply a continuous bead of sealer to the windshield opening flange on the car.
4. Install the rubber seal onto the glass. If there are outside windshield moldings that are held into position by the rubber seal then they must be installed at this time.

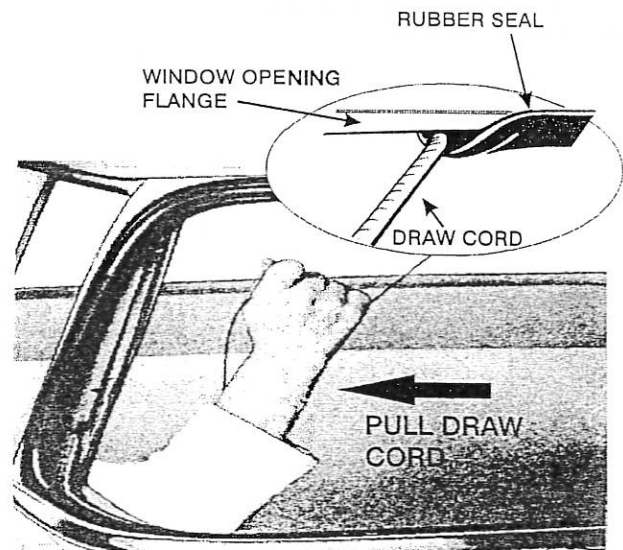

6. Position the glass assembly in the opening and have a helper apply pressure to the outside of the glass. From the inside, begin pulling the draw cord. This procedure allows the rubber seal to be pulled over the window opening flange area. Alternate from side to side when pulling the cord to keep the installation even. The draw cord operation will be completed at bottom center of the windshield. Pull the cord completely out of the rubber seal.
7. Once the windshield has been installed, tap the windshield around the perimeter with the palm of your hand to ensure that the rubber seal has been seated onto the window opening flange.



HELPFUL TIPS

Use masking tape to temporarily hold the seal onto the glass before installing the window. After the window has been installed the tape can be removed.

Typical draw cord installation

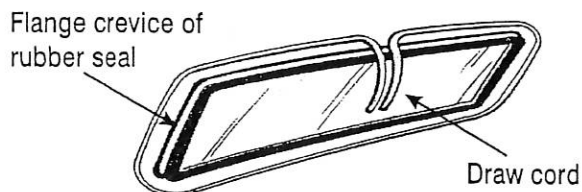

5. Apply a soap/water solution to the flange area of the rubber seal, then install a draw cord into the flange crevice of the rubber seal. Allow about 12 inches overlap at the top center



4140 Concord Parkway So., Concord, NC 28027
(704) 786-8139 email: info@dennis-carpenter.com
www.dennis-carpenter.com