

Installation of Fasteners for Tailgate Latch Handle Mounting Plate

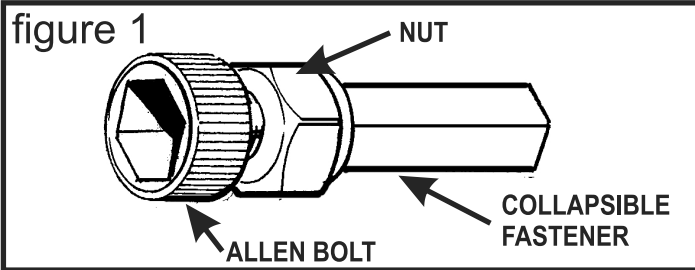

1. Thread the nut, then the collapsible fastener onto the Allen bolt as shown in figure 1.

NOTE: The Allen bolt should be threaded into the collapsible fastener so that the bolt end becomes flush with the fastener end.

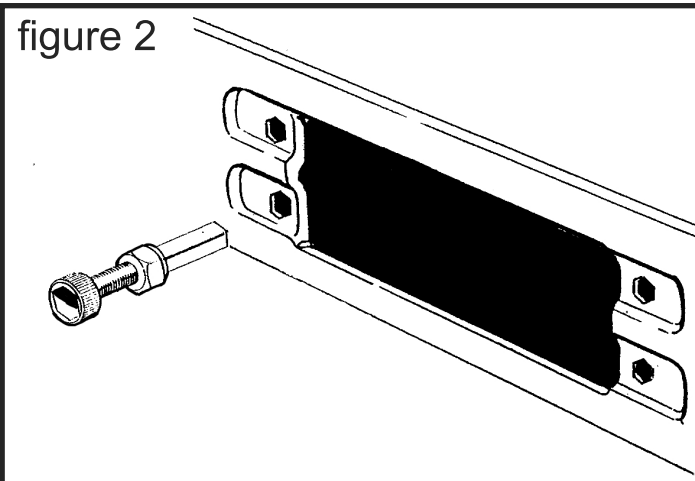

2. Insert the fastener assembly (shown in figure 2) into one of the four holes located in the center of the tailgate where the latch is located.

3. Using a 5/16" wrench, hold steady the collapsible fitting inside the tailgate. With a 7/16" wrench, turn the nut on the allen bolt clockwise tightening the nut. (figure 3)

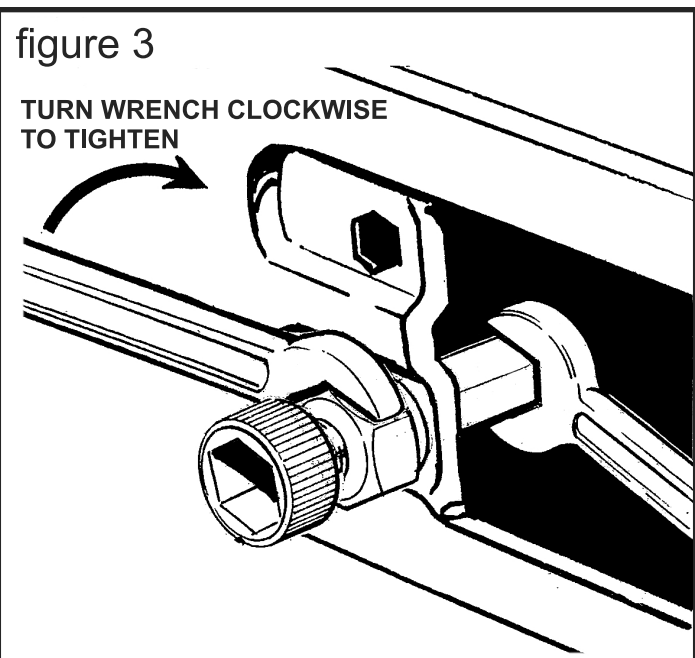

4. As the nut is turned, the fastener begins to draw into itself causing it to flare out. Continue tightening the nut until the fastener is secured to the tailgate. **DO NOT OVER TIGHTEN.**

The desired shape of the installed fastener is shown in figure 4.

5. After the fastener is secured, loosen the nut on the allen bolt. Using the appropriate allen wrench remove the bolt from the fastener.

6. Install the remaining three fasteners in the same manner as described in steps 1-5.

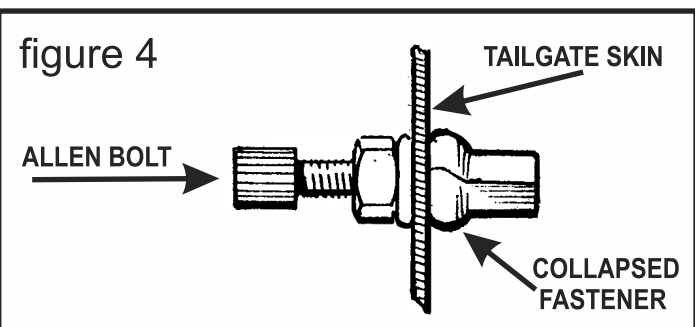

21 Carpenter Ct NW, Concord, NC 28027-4627
(704) 786-8139 email: info@dennis-carpenter.com
www.Dennis-Carpenter.com