

# GLASS WEATHERSTRIPPING INSTALLATION

The following procedures apply to and are the same for replacement of the short or long roof rear windows, the long roof side windows, and the lift gate windows.

When removing or installing a window, a helper must be employed to work outside the vehicle.

## REMOVING OLD WEATHERSTRIPPING

1. Working from the inside, start at one corner and work across the top of the glass, pulling the weatherstripping down and at the same time pushing the glass outward with light hand pressure until the helper can grasp the glass and lift it out of the opening.

2. Remove the old weatherstripping from the glass and clean any old sealer or adhesive from the glass.

## INSTALLING WEATHERSTRIPPING

1. It is recommended to "trial fit" the weatherstripping onto the glass before adding any sealers so as to locate any molded corners and to generally uncoil the weatherstripping.

2. Apply silicone sealant into the glass crevice of the weatherstripping and install it onto the glass. (see figure 1.)

3. Run a bead of silicone sealant around the opening flange crevice of the weatherstripping. (see figure 1.)

4. Beginning from the bottom center of the side of the glass which faces the interior, install a draw cord into the inner flange crevice of the weatherstripping completely around the glass and allow it to overlap the "beginning end" of the draw cord. (see figures 1 and 2.)

3. Apply a lubricant such as Ru-Glide or a soapy water solution to inner lip of the weatherstripping.

4. Have the helper position the window assembly into the window opening and apply hand pressure to the outside of the glass. From the inside of the vehicle, pull the lip of the weatherstripping over the window opening inner flange with the draw cord. Begin pulling the draw cord away from the center of the window assembly, alternating from side to side and moving about 12 inches at a time. This allows the inner lip of the weatherstripping to slip over the window opening inner flange. (see figure 3.) Continue pulling the draw cord around the window until the glass and weatherstripping become secured into the window opening.

5. Water test the installation for leaks, and apply additional sealer if necessary.

For weatherstripping:  
**C6TZ-9842084-B**  
**C6TZ-98305A26-B**  
**C7TZ-9742084-A**  
**C6TZ-98305A27-B**

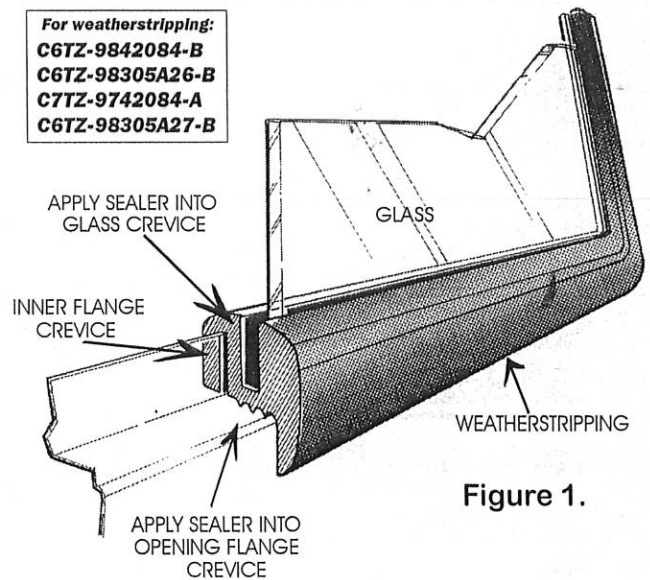

Figure 1.

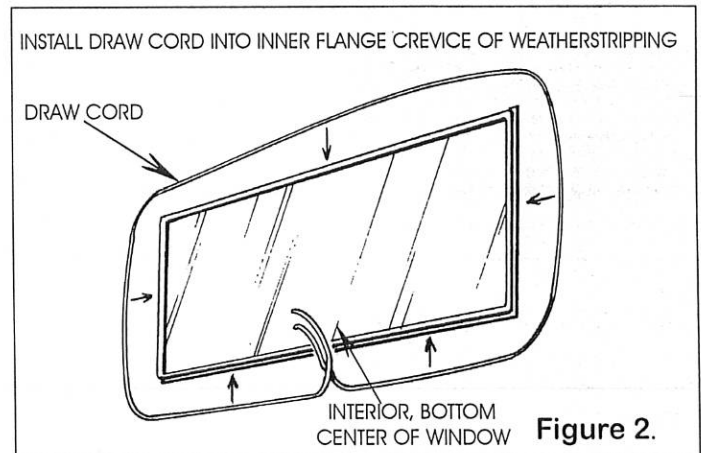

Figure 2.

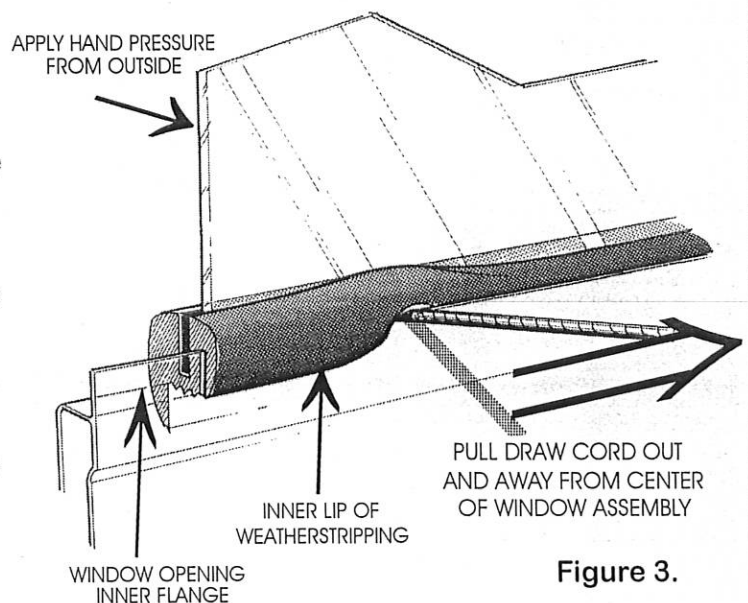

Figure 3.